

Sanitization of ÄKTAproucess with sodium hydroxide

This application note describes sanitization of ÄKTAproucess™ systems after infection with baker's yeast (*Saccharomyces cerevisiae*). The three systems tested were constructed of 10 mm polypropylene (PP); 3/8" and 1" stainless steel (SS), respectively.

The systems were infected with a solution containing approximately 1×10^6 viable organisms/ml of baker's yeast. The infected system was incubated for 16 to 20 h at room temperature, and then rinsed with purified water. Sanitization was performed by filling the system with 1 M NaOH at 75% of maximal system flow rate and then allowing an additional 1 h contact time (without flow). The efficiency of NaOH as sanitizing agent was evaluated by sampling at predetermined points in the system.

Each of the three systems was examined for colony forming units of baker's yeast at 57 sampling points and flowthrough was examined before and after infection. All inspected sampling sites were visually clean after sanitization and the results showed that 1 M NaOH effectively sanitized ÄKTAproucess of baker's yeast.

Introduction

ÄKTAproucess is an automated liquid chromatography system built for process scale-up and large-scale biopharmaceutical manufacturing. The system is available in three flow rate ranges that extend up to 1800 l/h for large volume manufacturing and can be constructed in either electropolished stainless steel or polypropylene, depending on process conditions and plant requirements.

Microorganisms, such as bacteria and yeasts are found in many laboratory and production environments and multiply rapidly after incubation. System sanitization is important since regulatory authorities have high standards for purity and low microbial presence in products used

in clinical applications. Therefore, the efficiency of the sanitizing method must be evaluated and this can be done by microbial challenge tests. Sodium hydroxide is frequently used to sanitize both chromatography equipment and media since it is documented as an effective sanitizing agent, is inexpensive, and readily available.

Microbial challenge tests

The principle of microbial challenge tests is to introduce a high concentration of microorganisms into the equipment or media and then treat with a sanitizing agent. After a specified length of time, samples are taken at predetermined sites, and the numbers of surviving organisms are counted.

In this study, baker's yeast (*Saccharomyces cerevisiae*) was selected as a challenging organism since yeast cells are more robust than other frequently used cells, such as *Escherichia coli* and Chinese Hamster ovary cells. After each infection, the three systems were sanitized by 1 M NaOH, rinsed, and microbial samples were taken at predetermined sites.

Sanitization and other terms

Sanitization, defined as the use of chemical agents to reduce microbial populations, is commonly used in chromatography systems to maintain microbial presence at a level that will minimize the risk of contaminating the product being processed. Note that a very low microbial level is generally acceptable to process operators and regulatory bodies, who do not require systems or equipment to be sterile or sterilizable. Sanitization, sterilization and other related terms are explained in Table 1.



Table 1. Explanation of relevant and related terms

Sanitization	The use of any chemical agent to reduce a microbial population.
Sterilization	The destruction or elimination of all forms of microbial life.
Disinfection	The destruction of potential pathogens.
Antimicrobial agent	An agent that minimizes or destroys microorganisms <i>in vitro</i> . The term antimicrobial is general and all-inclusive: antimicrobials include sanitizers, sterilizers and disinfectants. However, sanitizers, sterilizers and disinfectants are not necessarily the same and sanitization, sterilization and disinfection are not interchangeable terms.

Materials and Methods

Preparation of the test organism

For the microbial challenge test, baker's yeast (25% dry wt.) was diluted with sterile 50 mM NaCl to an approximate concentration of 1×10^6 viable organisms/ml. The concentration was determined by viable count (see sampling method 4 in Microbial sampling).

Preparation and infection of the system

The system was prepared for sanitization by connecting manifolds at the system inlets, outlets and column in/out. The inlet manifolds were then connected by tubing to the CIP inlet valves and tanks filled with sanitization and rinsing solutions were connected to the CIP inlet valves (Fig 1). All tubing had metal fittings since some plastics have low chemical resistance to 1 M NaOH. Prior to sanitization, the filter was removed. Note that if biomass film is found at the bottom of the filter housing, we recommend that the surface is sprayed with 70% ethanol and wiped clean. Finally, the pH electrode was replaced with a plug to avoid damage at extreme pH.

The detachable parts of the system were disassembled and sprayed with 70% ethanol before reassembling. The whole system was then filled with 1 M NaOH and allowed to stand still for 16 to 18 h and then rinsed with purified water until pH was neutral. The challenge organism suspension was pumped into the system at a flow rate between 33% and 50% of maximal flow rate. The air trap was filled to ordinary operating level and the filter housing was in line (but without filter). The systems were incubated without flow for 16 to 20 h at room temperature.

Sanitization procedure

After incubation, the system was rinsed with purified water and filled with 1 M NaOH at 50 to 75% of maximal system flow rate. The air trap and the filter housing were over-filled. After the filling with NaOH, the system stood without flow for 1 h. The procedure was finished by rinsing with sterile water to achieve neutral pH before sampling.

Microbial sampling

Microbial samples were taken at 57 predetermined sampling points (Fig 1 and Table 2); flowthrough samples were also taken at infection; post-infection, and post-sanitization (Table 3). The following methods were used to estimate the numbers of challenging organisms:

Sampling method 1 – direct filtration

Sample solutions (minimum 10 ml) were collected in sterile tubes and then filtered through a 0.45 μm cellulose nitrate membrane filter. The filter was washed with 100 ml sterile 0.9 mg/ml NaCl solution and then incubated on malt extract agar plates at 30°C to 35°C for 5 d before the number of CFU (Colony Forming Units) was counted and the number of viable microorganisms in the sample was calculated.

Sampling method 2 – swab

Surface samples were taken with alginate swabs. The swab was inserted into the tube containing the isotonic swab rinse solution. After dissolution, the whole solution was put into molten malt extract agar and allowed to solidify in Petri dishes. The plates were incubated at 30°C to 35°C for 5 d before the number of CFU was counted and the number of viable microorganisms in the sample was calculated.

Sampling method 3 – peptone water filtration

Detachables parts were aseptically removed and put in 50 ml sterile peptone water in a 250 ml Erlenmeyer flask. The flask was vigorously shaken for at least 20 min and then the peptone water was filtered through a 0.45 μm cellulose nitrate membrane filter. The filter was washed with 100 ml sterile 0.9 mg/ml NaCl solution and then incubated on malt extract agar plates at 30°C to 35°C for 5 d before the number of CFU was counted and the number of viable microorganisms in the sample was calculated.

Sampling method 4 – viable count

Samples of the yeast solution, infection sample, and flowthrough were diluted and incubated on malt extract agar plates at 30°C to 35°C for 1 to 2 d before the number of CFU was counted and the number of viable microorganisms in the sample was calculated.

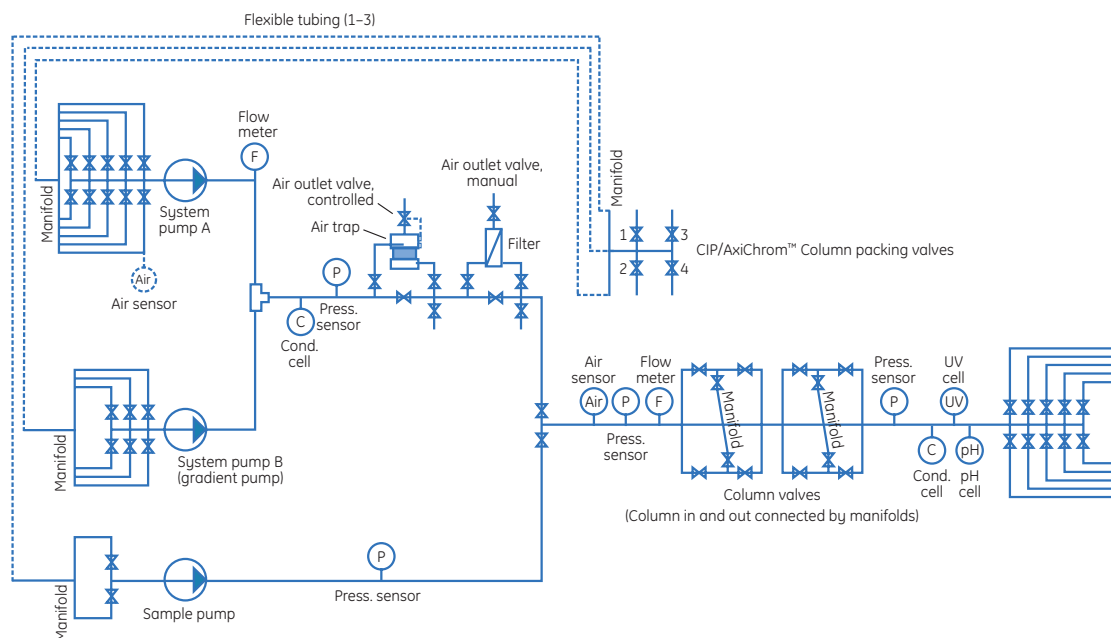

Fig 1. The ÄKTApocess flow scheme.

Results

The results of the microbiological sampling that showed that treatment with 1 M NaOH for 1 h efficiently sanitized all the 57 sampling points in each system.

All inspected sampling sites were visually clean after sanitization except for biomass in the bottom of the filter housing (Table 2). Note that if biomass film is found at

the bottom of the filter housing, we recommend that the surface is sprayed with 70% ethanol and wiped clean.

The results in Table 3 show that all three systems had infection and post-infection solutions with approximately 1×10^6 viable organisms/ml of baker's yeast. After sanitization treatment the concentration of challenging organisms in the flowthrough solutions was zero.

Table 2. Number of CFU of baker's yeast remaining after sanitization

	No. of sampling points	Sampling method	10 mm PP (CFU/ml or CFU/sampled unit)	3/8" SS (CFU/ml or CFU/sampled unit)	1" SS (CFU/ml or CFU/sampled unit)
Inlet valve	6	2, 3	0	0	0
System pump A	7	2, 3	0	0	0
Cond. cell	4	2, 3	0	0	0
Press. sensor	5	2, 3	0	0	0
Air trap	16	2, 3	0	0	0
Filter housing	4	2	0 ¹	0 ¹	0 ¹
Air sensor	1	2	0	0	0
Column valve	2	2	0	0	0
pH-cell	4	2, 3	0	0	0
UV flow cell	2	2	0	0	0
Outlet valve	6	2, 3	0	0	0

Σ 57

¹ visual biomass

Table 3. Number of CFU of baker's yeast in flowthrough at different phases of sanitization

Sanitization phase	Sampling method	10 mm PP <i>S. cerevisiae</i> (CFU/ml)	3/8" SS <i>S. cerevisiae</i> (CFU/ml)	1" SS <i>S. cerevisiae</i> (CFU/ml)
Infection/start concentration	4	3.4×10^6	3.9×10^6	1.9×10^6
Post-infection, flowthrough sample	4	4.0×10^6	3.2×10^6	3.1×10^6
Post-sanitization flowthrough sample	1	0	0	0

Conclusions

The results show that the three sizes of ÄKTApocess systems examined can be efficiently sanitized with 1 M NaOH and the recommended procedure after contamination with high concentrations of baker's yeast. However, the sanitization method cannot alone guarantee good hygienic status of a chromatographic process. It should always be applied in conjunction with other well-designed and carefully controlled hygienic routines, as well as rigorous control of buffers, water, and other input material.

www.gehealthcare.com/protein-purification-bioprocess

GE Healthcare Bio-Sciences AB
Björkgatan 30
751 84 Uppsala
Sweden

ÄKTApocess and AxiChrom are trademarks of GE Healthcare companies. GE, imagination at work, and GE monogram are trademarks of General Electric Company.

All goods and services are sold subject to the terms and conditions of sale of the company within GE Healthcare that supplies them. General Electric Company reserves the right, subject to any regulatory and contractual approval, if required, to make changes in specifications and features shown herein, or discontinue the product described at any time without notice or obligation. Contact your local GE Healthcare representative for the most current information.

© 2006 General Electric Company – All rights reserved.

GE Healthcare Bio-Sciences AB, a General Electric Company.

GE Healthcare Europe GmbH
Munzinger Strasse 5, D-79111 Freiburg, Germany

GE Healthcare UK Ltd
Amersham Place, Little Chalfont, Buckinghamshire, HP7 9NA, UK

GE Healthcare Bio-Sciences Corp
800 Centennial Avenue, P.O. Box 1327, Piscataway,
NJ 08855-1327, USA

GE Healthcare Bio-Sciences KK
Sanken Bldg. 3-25-1, Hyakunincho, Shinjuku-ku,
Tokyo 169-0073, Japan

Asia Pacific T +85 65 62751830 F +85 65 62751829 • Australasia T +61 2 8820 8299 F +61 2 8820 8200 • Austria T 01/57606 1613 F 01/57606 1614 • Belgium T 0800 73 890 F 02 416 8206 • Canada T 1 800 463 5800 F 1 800 567 1008 • Central & East Europe T +43 1 972 720 F +43 1 972 722 750 • Denmark T +45 70 25 24 50 F +45 45 16 2424 • Eire T 1 800 709992 F +44 1494 542010 • Finland & Baltics T +358 9 512 3940 F +358 9 512 39439 • France T 01 69 35 67 00 F 01 69 41 98 77
Germany T 0800 9080 711 F 0800 9080 712 • Greater China T +852 2100 6300 F +852 2100 6338 • Italy T 02 26001 320 F 02 26001 399 • Japan T 81 3 5331 9336 F 81 3 5331 9370 • Korea T 82 2 6201 3700 F 82 2 6201 3803 • Latin America T +55 11 3933 7300
F +55 11 3933 7304 • Middle East & Africa T +30 210 96 00 687 F +30 210 96 00 693 • Netherlands T 0800-82 82 82 1 F 0800-82 82 82 4 • Norway T +47 815 65 777 F +47 815 65 666 • Portugal T 21 417 7035 F 21 417 3184 • Russia, CIS & NIS
T +7 495 956 5177 F +7 495 956 5176 • Spain T 902 11 72 65 F 935 94 49 65 • Sweden T 018 612 1900 F 018 612 1910 • Switzerland T 0848 8028 10 F 0848 8028 11 • UK T 0800 515 313 F 0800 616 927 • USA T +1 800 526 3593 F +1 877 295 8102

